

ASSEMBLY MANUAL

JUMPING OVAL

2.4 x 3.5 m / 8 x 11.5 ft

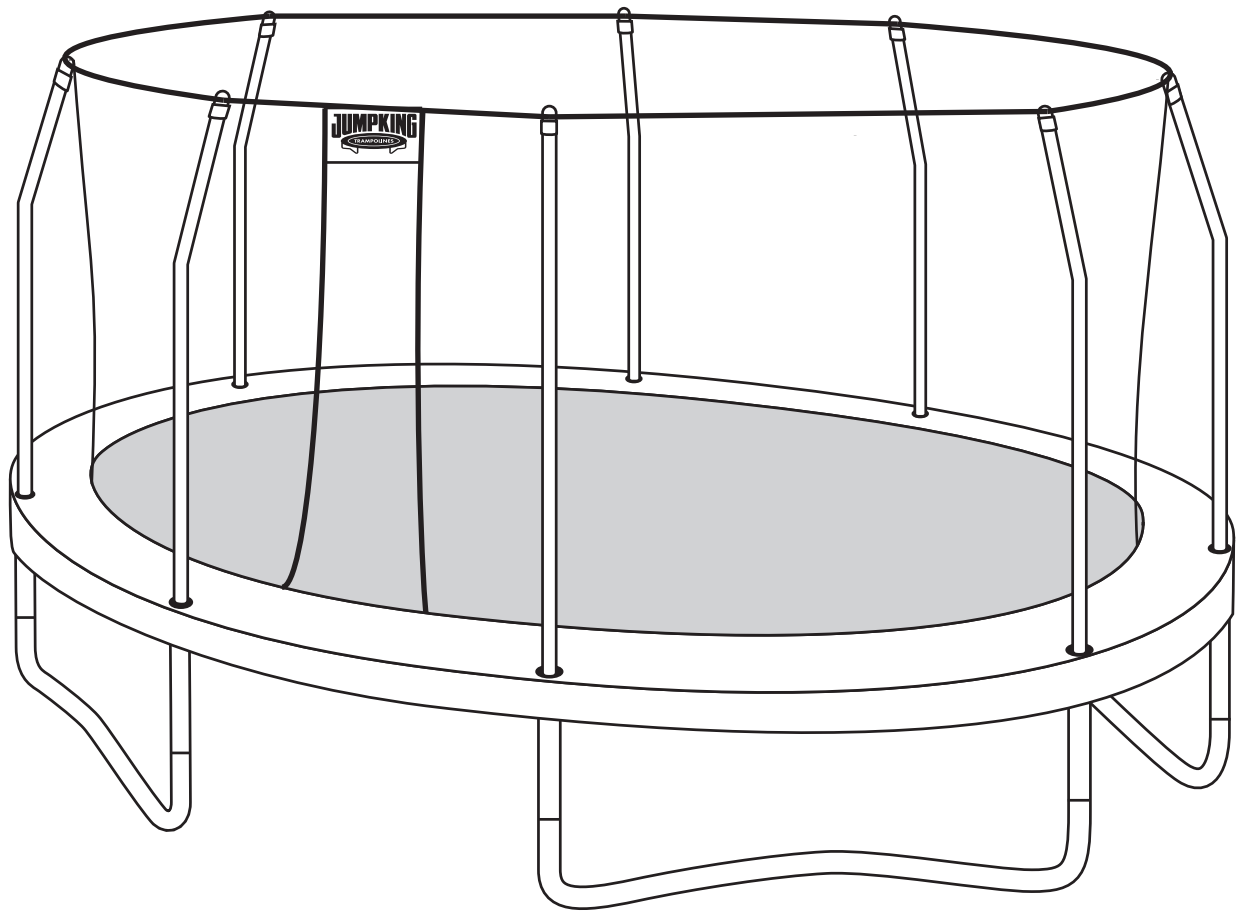

Important information

WARNINGS!

- Only for domestic use.
- Maximum user weight limit 115 kg.
- Not suitable for children under 36 months - small parts, choking hazard.
- Outdoor use only.
- The trampoline should be assembled by an adult in accordance with assembly instructions and checked before each use.
- Only one user. Collision hazard.
- Always close the net opening/door before jumping.
- Remove footwear before jumping on the trampoline.
- Do not use the mat / jumping bed when it is wet.
- Empty pockets and hands before jumping.
- Always jump in the middle of the mat / jumping bed.
- Do not eat while jumping.
- Do not exit by a jump.
- Limit the time of continuous usage (make regular stops).
- Do not use in strong wind conditions and secure the trampoline.

ADVISORY

- This trampoline is not intended to be buried in the ground.
- The following product dimensions relate to this 8x11.5ft oval trampoline:
 - Height from ground to top rail: 76 cm top rail of trampoline
 - Height from ground to top of enclosure: 263 cm
 - Height from top rail to top of enclosure: 187 cm top rail of trampoline
- The trampoline must be placed on a level surface at least 2m from any structures or obstructions such as fence, garage, house, overhanging branches, laundry lines or electrical wires.
- Do not install the trampoline over concrete, asphalt or any other hard surface. Also not in proximity of other conflicting installations, such as swimming pools, swings, slides or climbing frames.
- Inspect trampoline / enclosure net before each use.
- Any damaged or worn parts must be replaced before using the trampoline.
- If an access ladder is used it should be removed when trampoline is not in use.
- Make sure there are no children / animals / obstructions underneath the trampoline.
- Access the trampoline through the door of the enclosure net only. Making sure you securely close it before bouncing. Use: Ensure the door is securely closed before bouncing.
- Do not use in strong wind conditions and secure the trampoline.
- Don't intentionally rebound off the enclosure net as this will weaken it.
- Only attach manufacturer approved accessories to the trampoline and enclosure net.
- Always jump in the middle of the mat and practice bounce techniques safely with adult supervision and guidance.

For mer informasjon, vennligst se vår hjemmeside: www.jumpking.no

För mer information, besök vår hemsida: www.jumpking.se

Lisätietoja tutustumalla verkkosivulla: www.jumpking.fi

For mere information, besøg venligst vores hjemmeside: www.jumpkingtrampolines.dk

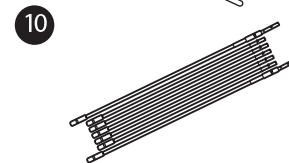
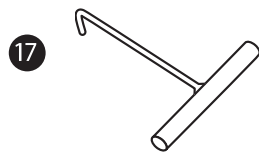
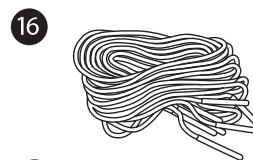
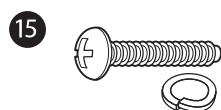
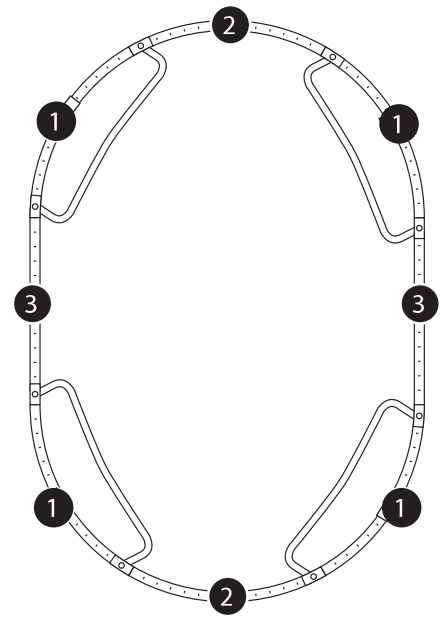
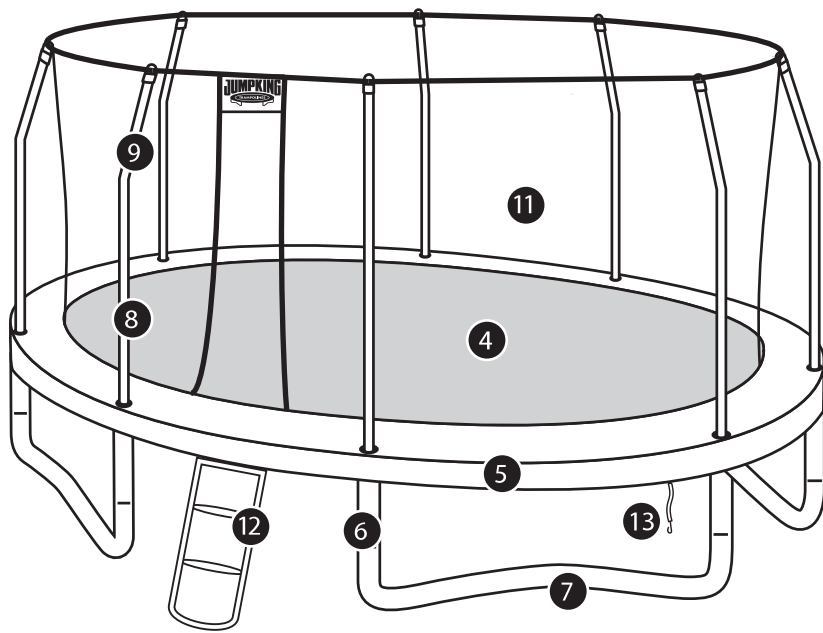

Key no.	Description	Qty
1	Top Pipe "A"	4
2	Top Pipe "B"	2
3	Top Pipe "C"	2
4	Bed with V-ring	1
5	Frame Pad	1
6	Straight Leg	8
7	W-Leg	4
8	Enclosure Straight Foam Tube	8
9	Enclosure Top Curved Foam Tube	8
10	Black G4 FRP pole	2

Key no.	Description	Qty
11	Safety Net	1
12	Ladder	1
13	Frame Pad Strap	16
14	Spring 7" (18 cm)	70
15	Self tapping screw and washer	24
16	Cord	6
17	Spring Pulling Tool	1
18	Cap (if the Enclosure is not mounted)	8

1

Watch Video



[jumpking.wistia.com/
medias/cr4svo1wuj](https://jumpking.wistia.com/medias/cr4svo1wuj)

2x

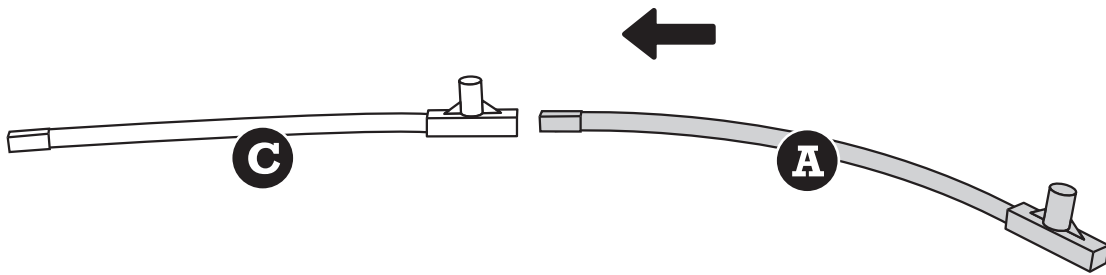

2

2x

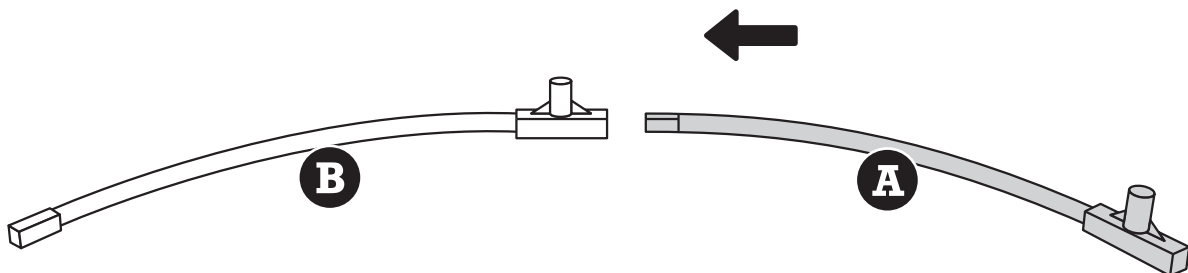

3

4x

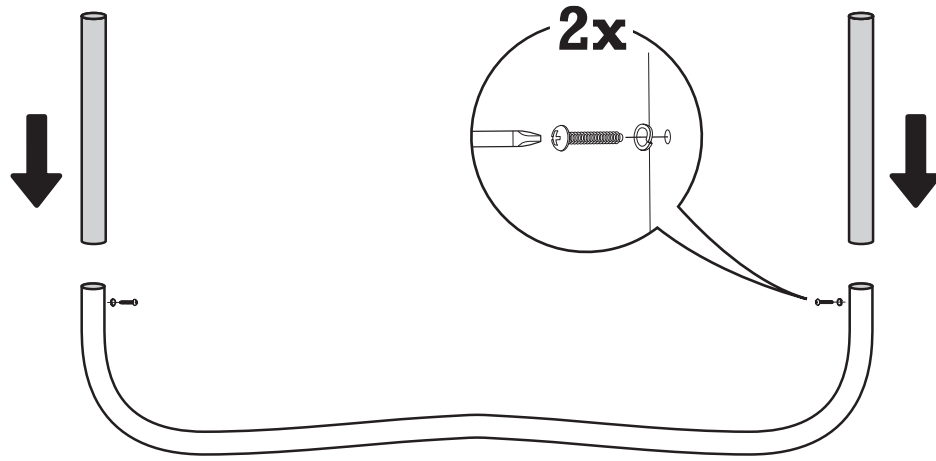

4

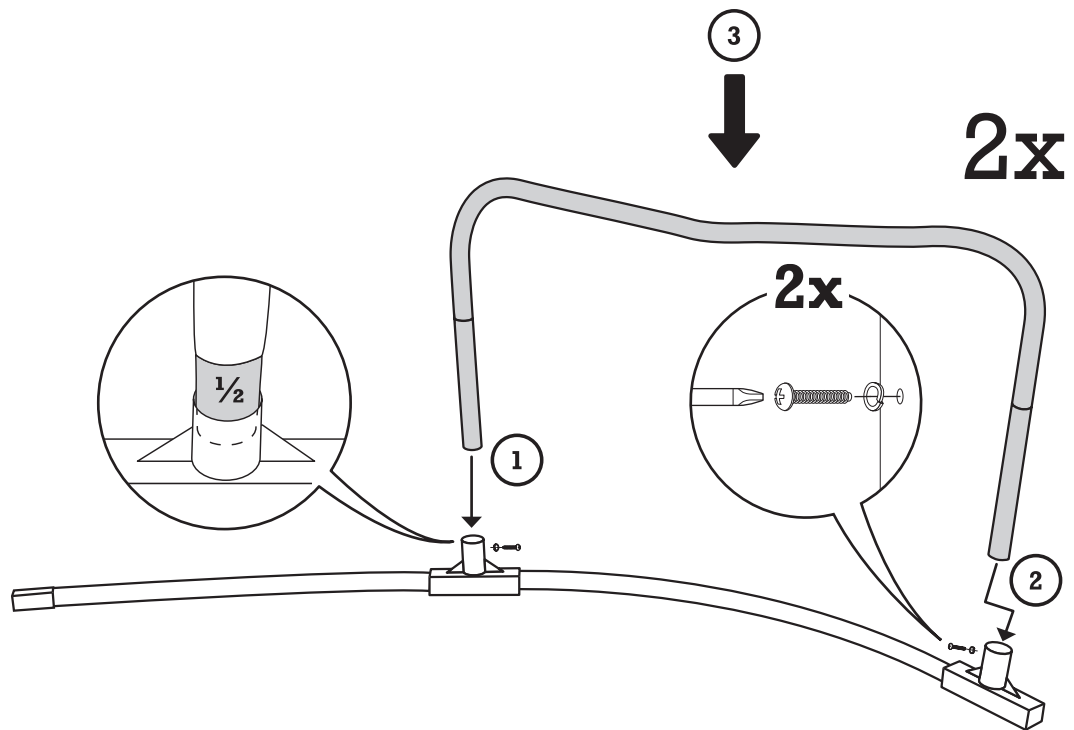

5

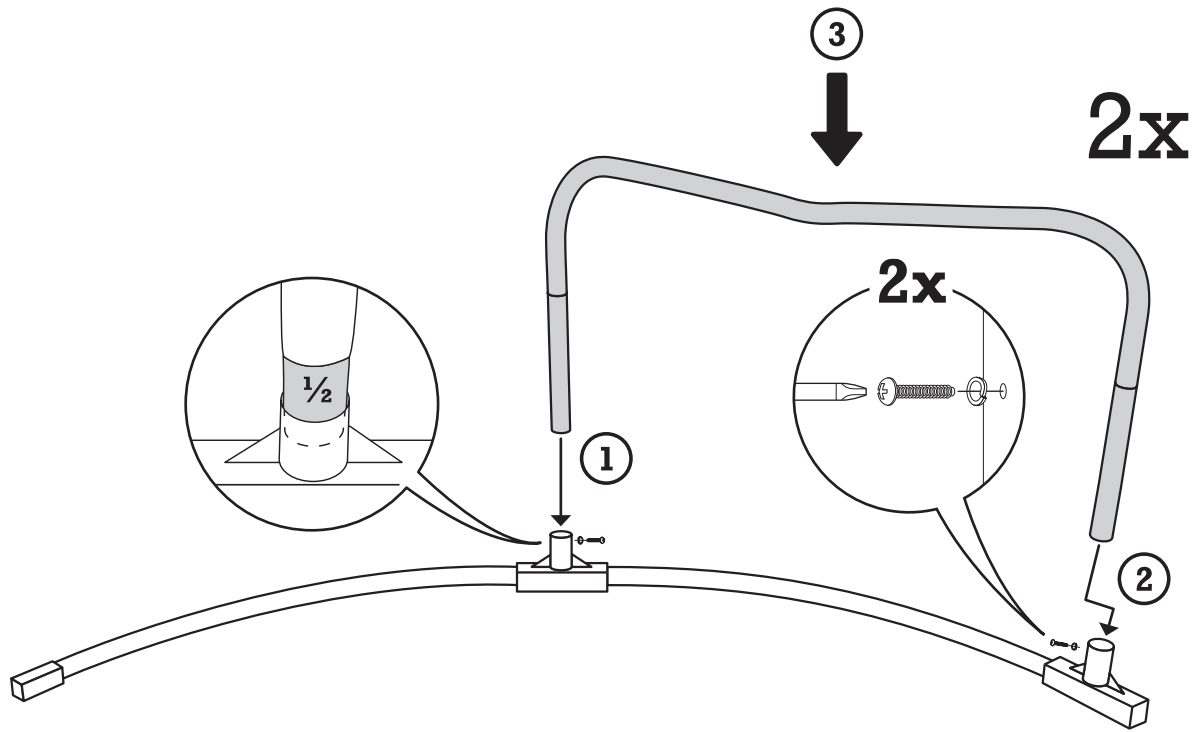

6

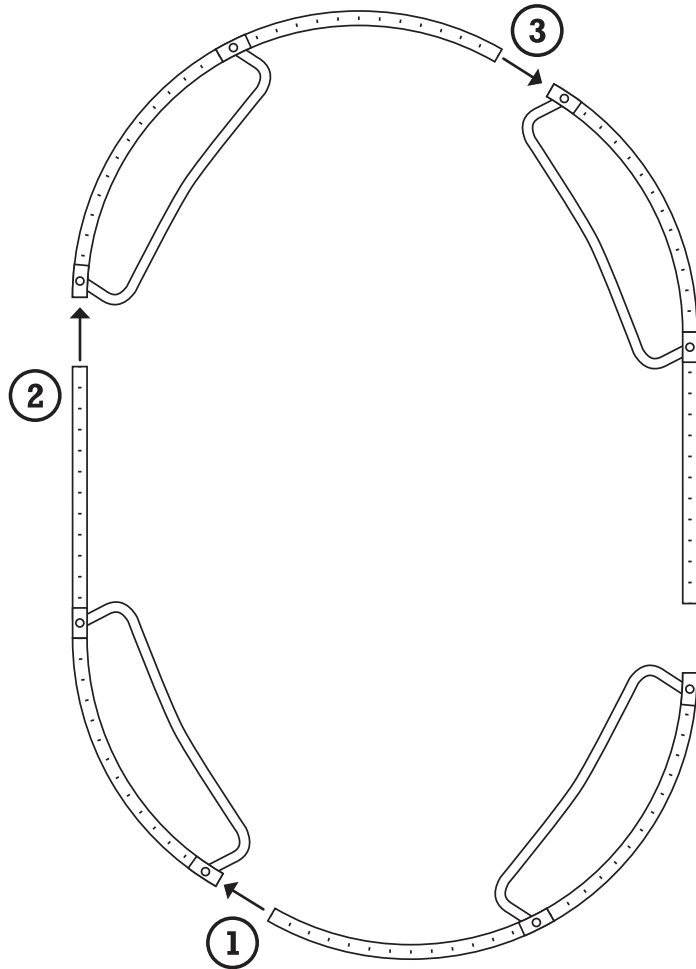

7

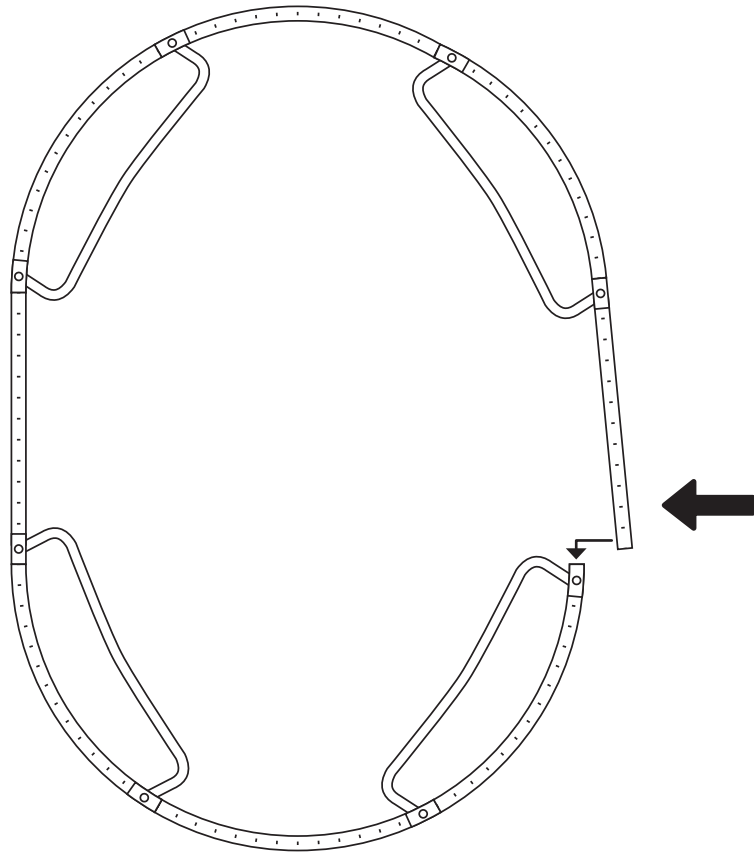

Watch Video



jumpking.wistia.com/medias/wfzd9dnde6

8

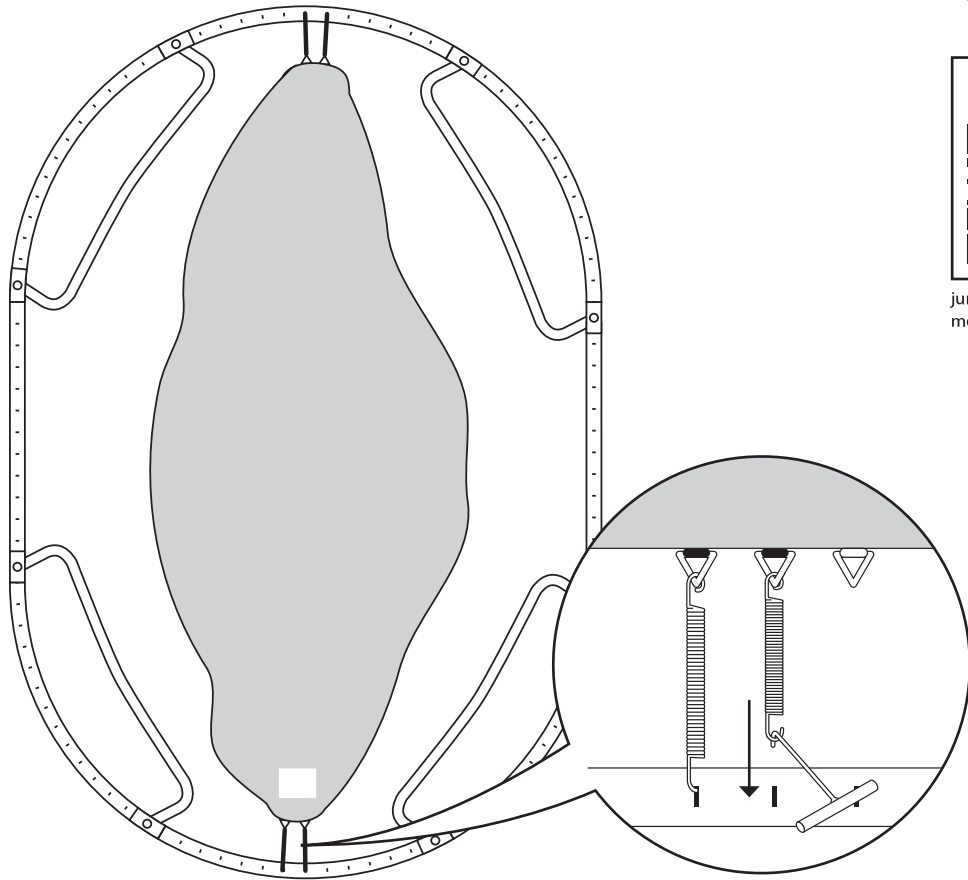

Watch Video



jumpking.wistia.com/medias/x1dbv1hurz

9

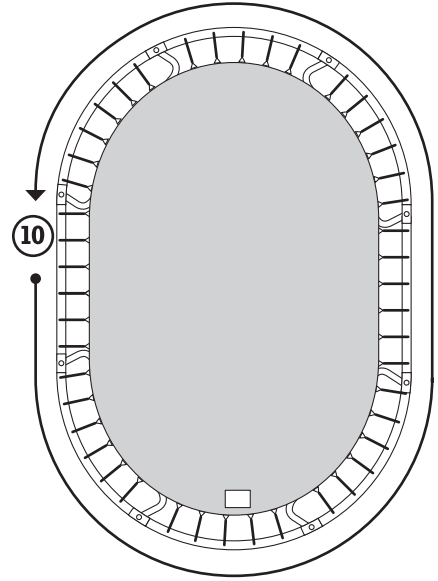
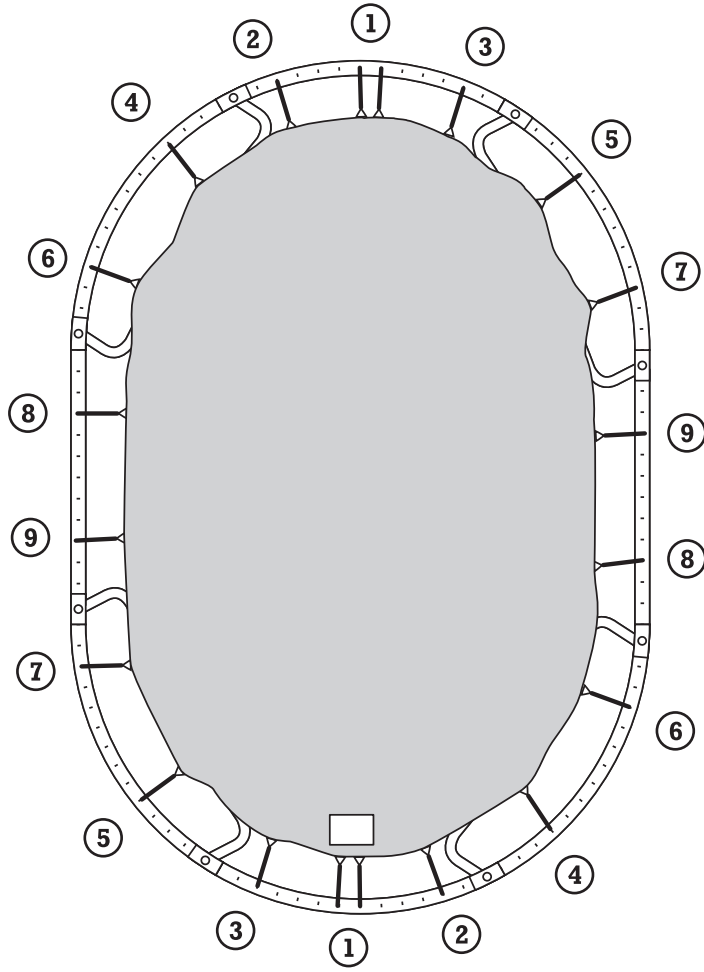

10

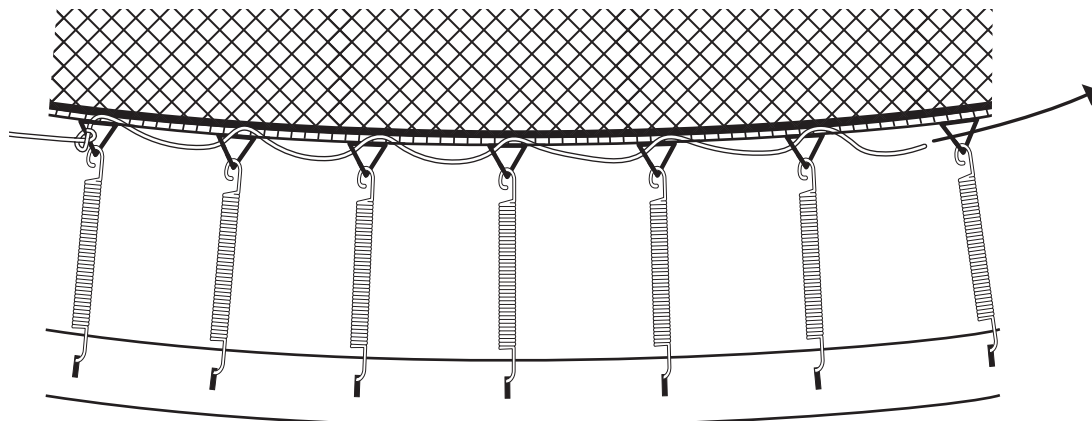
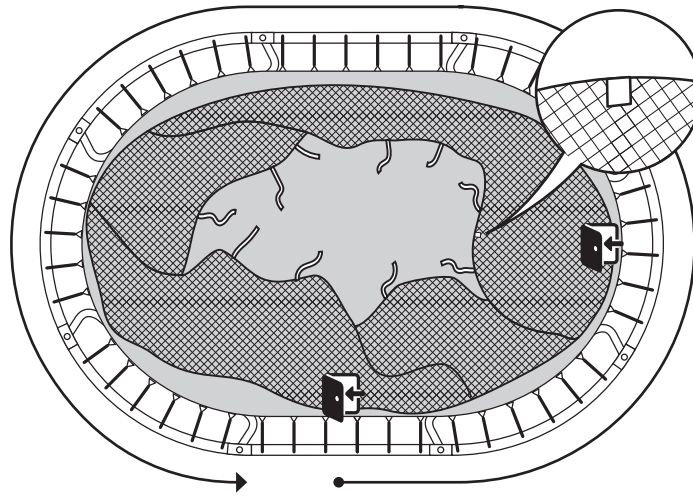

Watch Video



[jumpking.wistia.com/
medias/d2bch6h4td](https://jumpking.wistia.com/medias/d2bch6h4td)

11

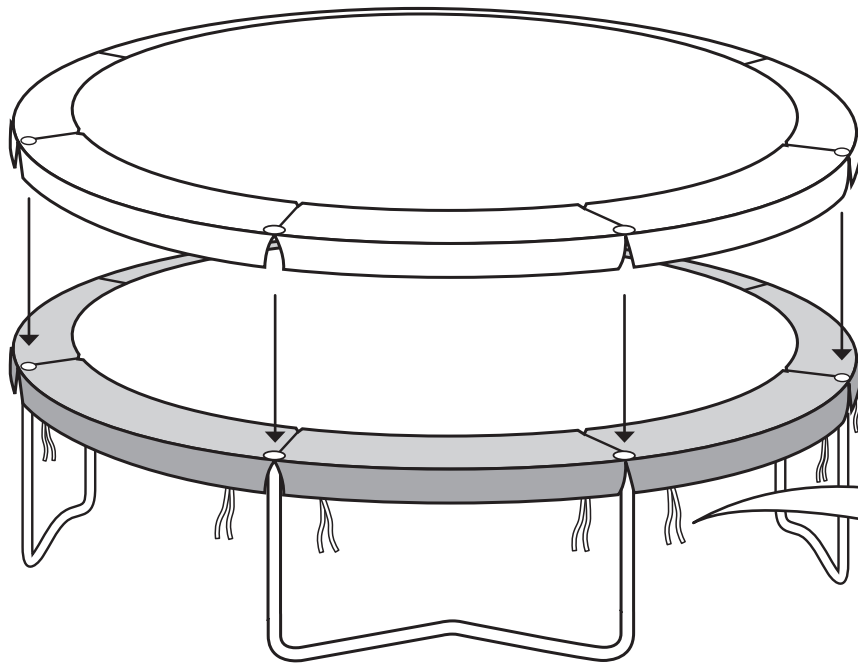

Watch Video



jumpking.wistia.com/medias/ej1qaktla8

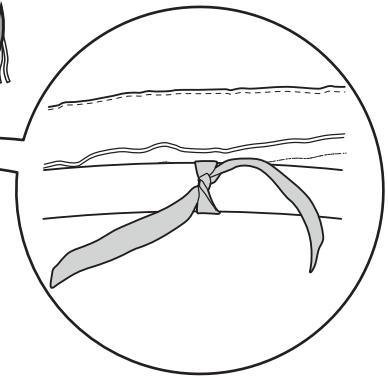

12

8x

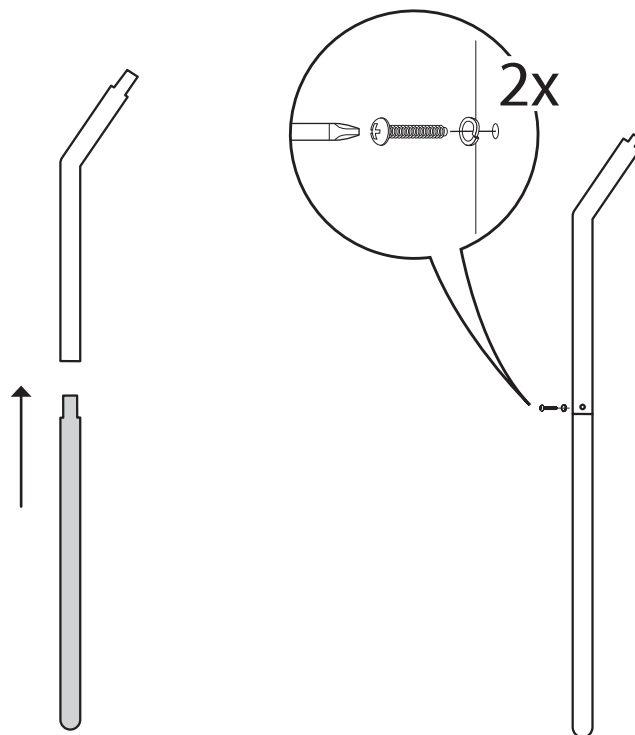

Watch Video



jumpking.wistia.com/medias/gy93mfejm

13

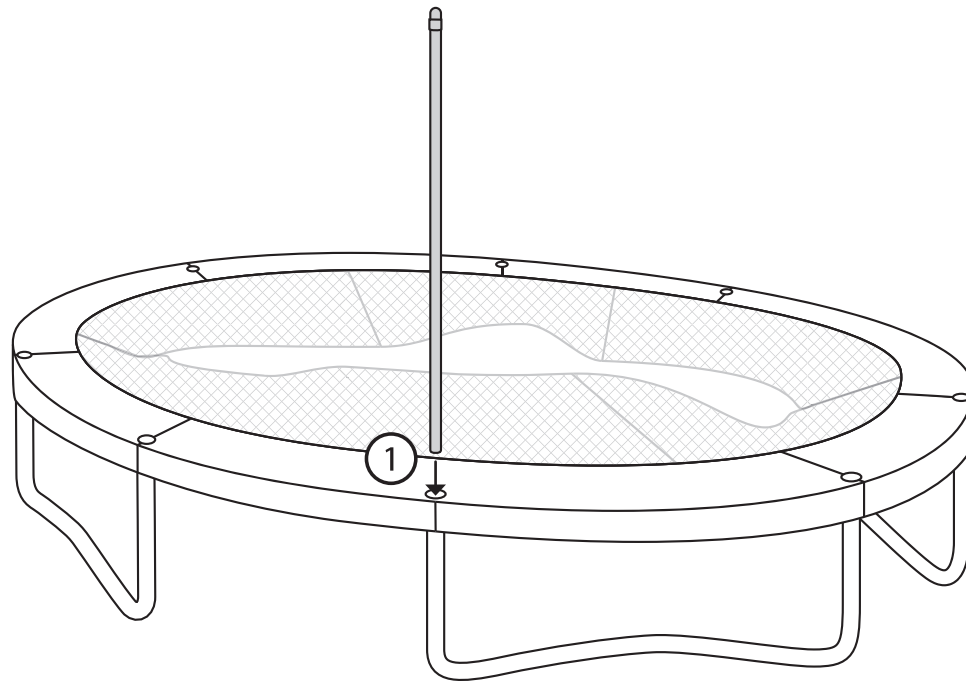

14

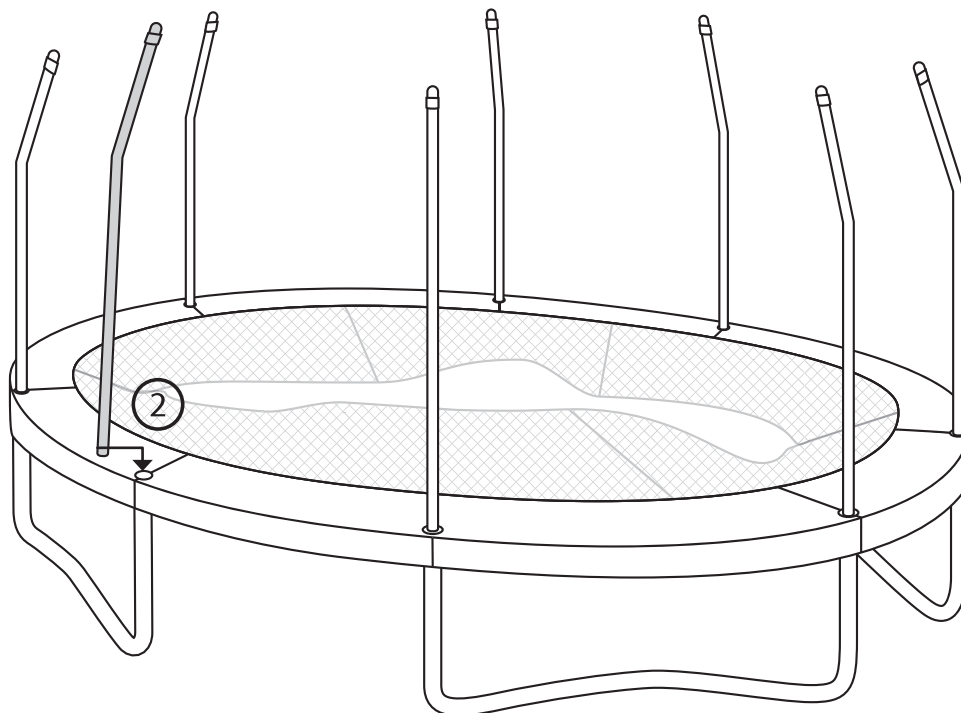

15

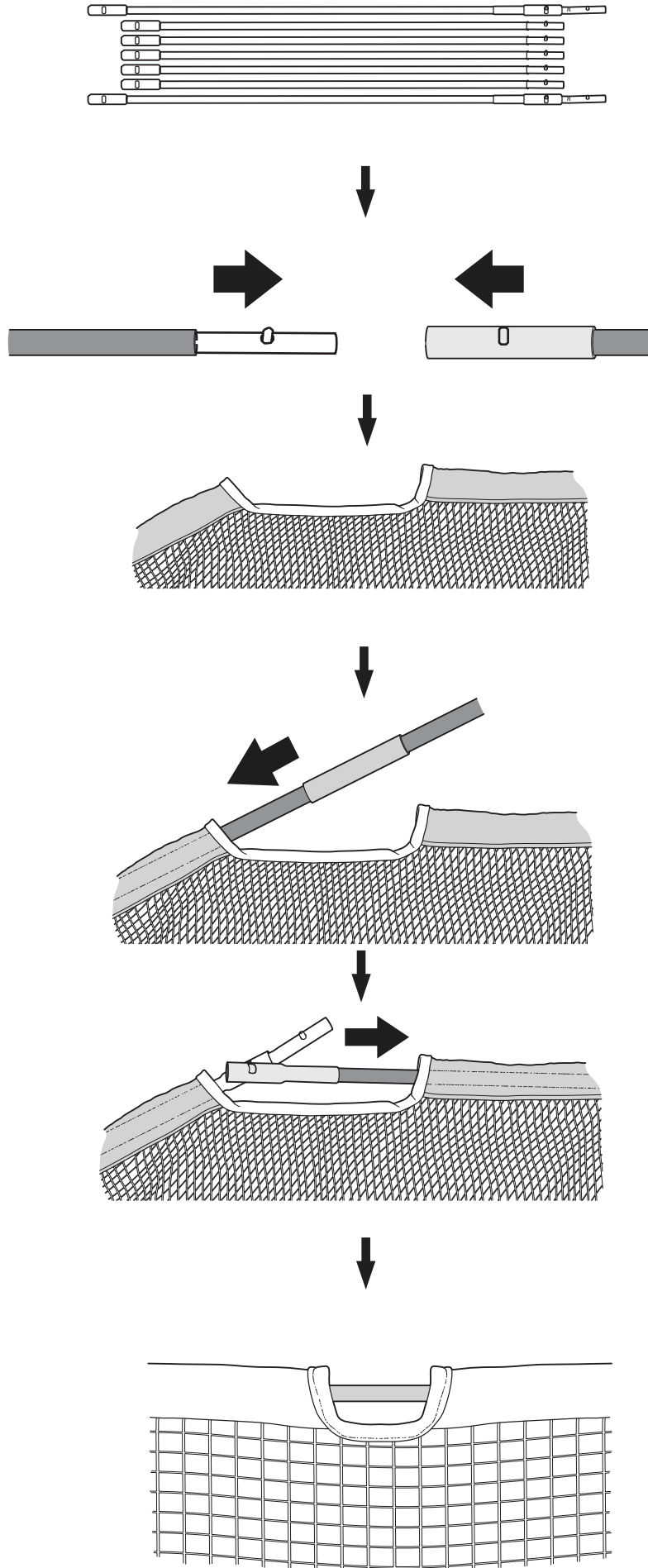

16

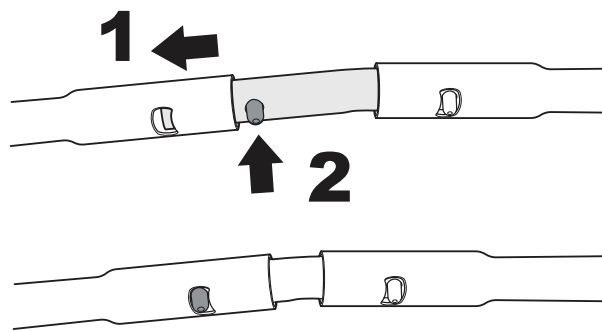
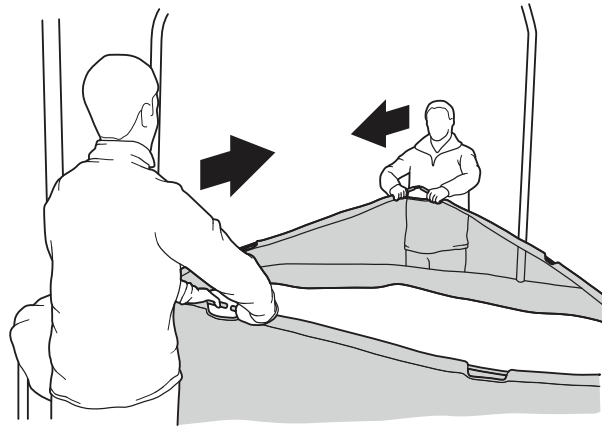

17

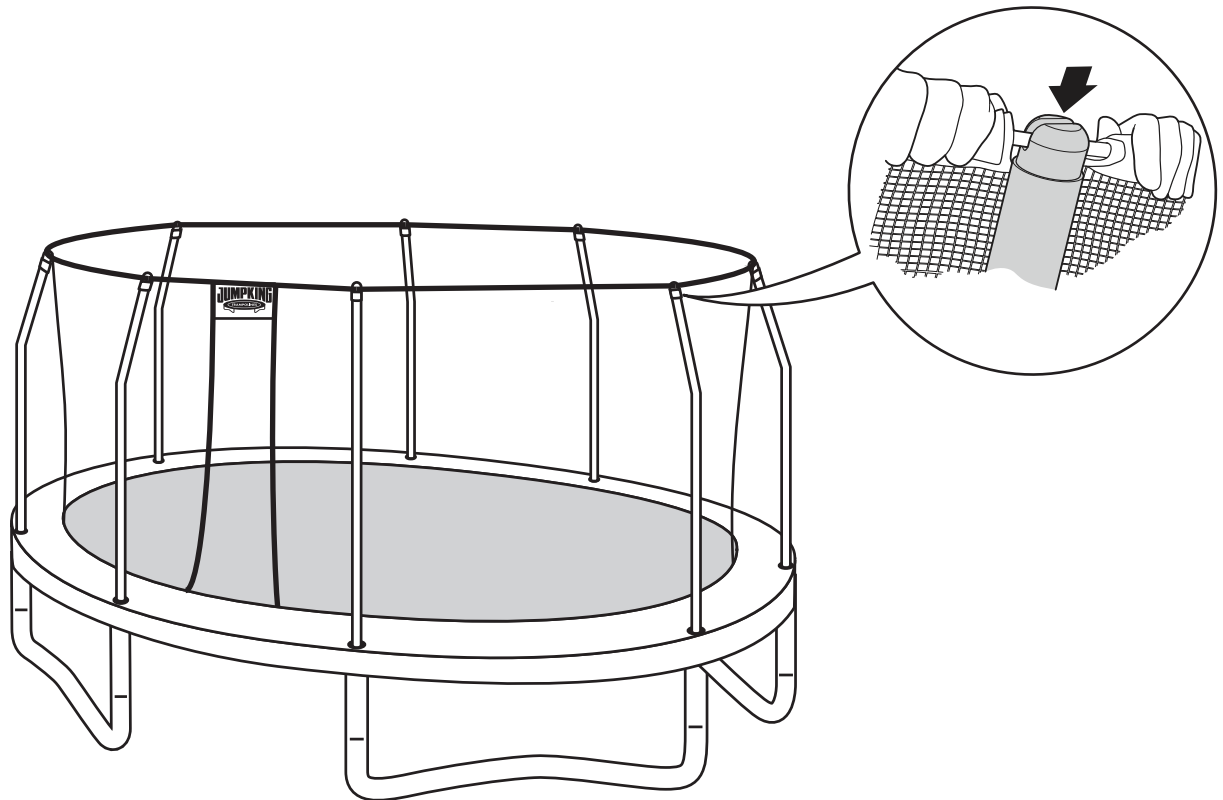

Care and maintenance

Regular care and maintenance of your trampoline is required. This will help prolong its life and reduce the possibility of injury. Neglecting this can lead to a risk for users. Inspect your trampoline before each use using the checklist below as a guide. Take particular care in doing this at the start of each season and at regular intervals. Ensure all parts are intact and cannot become dislodged during play. Tighten any screws or nuts and bolts where required.

IMPORTANT: If any faults are found, the trampoline **MUST NOT BE USED**. We advise that the trampoline is dismantled and placed in a dry place until new parts are fitted.

Looking after your trampoline

- **Use trampoline as advised on page 2.**
Excess weight and improper use can damage the trampoline and possibly cause injury.
- **Keep the trampoline clean.**
If any part becomes dirty, clean with a damp cloth and dry thoroughly. Do not use any abrasive cleaners as this could damage the product.
- **Keep bed/jumping mat in good condition.**
Common damage can be caused by water pooling, garden/outdoor debris landing on it, sparks from nearby bonfires or firework displays landing on it. Keep animals/pets away from the trampoline as their claws can damage the bed.
- **Protect from high winds.**
A trampoline can act like a sail in strong winds. It can be blown over which can cause damage to the frame and surrounding areas. We recommend that it is moved to a sheltered location and secured to the ground (tie-down kits are available from our website), or dismantled and stored away.
- **Dismantle and store away in dry place if not being used for long periods.**
Follow assembly instructions in reverse order making sure the springs are removed before dismantling frame. Prolonged exposure to sun and harsh weather can shorten the life of the safety net.
- **Take care when moving the trampoline.**
To be lifted by 2 or more people. Lift slightly off the ground, keeping the frame horizontal. Never drag to move it as this can displace parts. Always check that parts are positioned correctly after moving.

For mer informasjon, vennligst se vår hjemmeside: www.jumpking.no

För mer information, besök vår hemsida: www.jumpking.se

Lisätietoja tutustumalla verkkosivulla: www.jumpking.fi

For mere information, besøg venligst vores hjemmeside: www.jumpkingtrampolines.dk



ALWAYS A JUMP AHEAD

Norway

JumpKing AS
Ramstadsletta 10
1363 HØVIK
Norge

+47 67-15 16 17
www.jumpking.no

Sweden

Jumpking Studsmattor AB
Kärrlyckegatan 29B
418 78 Göteborg
Sverige

+46 31-762 25 22
www.jumpking.se

Denmark

Jumpking Studsmattor AB
Kärrlyckegatan 29B
418 78 Gothenburg
Sweden

+46 31-762 25 22
www.jumpkingtrampolines.dk

Finland

Jumpking Studsmattor AB
Kärrlyckegatan 29B
418 78 Gothenburg
Sweden

+46 31-762 25 22
www.jumpking.fi